



Refrigerator 2039 000

Refrigerators

Code: 2039 000



DETAILS

Supply 220-230V - 50Hz

Alarms Double alarm: door open / temperature

Freezing capability 10Kg / 24h

Total gross capacity 235Lt

Freezer net Capacity 212Lt

Hinges Slide

Climate class SN/T (tropical +10°C/+43°C)

Energy class A+

Annual energy consumption 277kWh

Dimensions 540x1772x545 mm

Lighting LED

Door Reversible - std hinges on the right

Noise level 39dB(A)

Control type Electronic control with LED display

Fridge type single-door built-in freezer

Type Built-in drawer freezer

FEATURES

Advanced fast freeze These functions are available on models with digital programming; they respectively allow the freezing and quick cooling of large quantities of food.

No-frost freezer The No-Frost technology removes moisture from the freezer with a forced ventilation system in controlled temperature and humidity conditions. No more ice that reduces the usable volume, glues packings one to the other and compromises performance.

TECHNICAL DATA

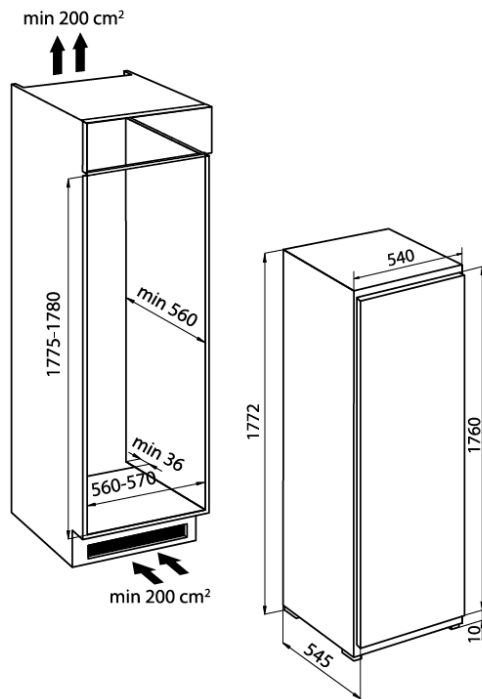

OPTIONAL ACCESSORIES



Kit for side by side installation
2038 039